

1 General

| | | |
|-------------------------------------|------------------------|--|
| Fan type | Fan | |
| Rotating direction looking at rotor | Counterclockwise | |
| Airflow direction | Air outlet over struts | |
| Bearing system | Ball bearing | |
| Mounting position - shaft | Any | |

2 Mechanics

2.1 General

| | | |
|---|---|--|
| Depth | 51,0 mm | |
| Diameter | 172,0 mm | |
| Mass | 0,900 kg | |
| Housing material | Metal | |
| Impeller material | Plastic | |
| Max. torque when mounted across both mounting flanges | Wire outlet corner: 600 Ncm Remaining corners: 600 Ncm | |
| Screw size | ISO 4762 - M4 degreased, without an additional brace and without washer | |

2.2 Connections

| | | |
|-----------------------|-------------|--|
| Electrical connection | Wires | |
| Lead wire length | L = 365 mm | |
| Tolerance | + - 10,0 mm | |
| Tube length | S = 10 mm | |
| Tolerance | + - 2,0 mm | |

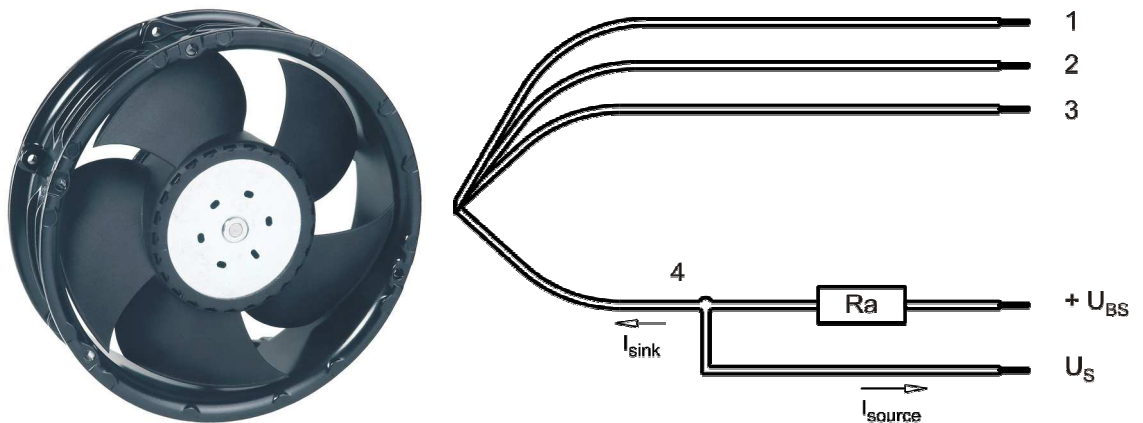

| Wire | Color | Operation | Wire size | Insulation diameter |
|------|--------|-----------|-----------|---------------------|
| 1 | red | + UB | AWG 22 | 1,7 mm |
| 2 | blue | - GND | AWG 22 | 1,7 mm |
| 3 | violet | PWM | AWG 22 | 1,7 mm |
| 4 | white | Tacho | AWG 22 | 1,7 mm |

The auxiliaries shown on the schematic diagram (which are required for the intended use) are not part of our delivery.

3 Operating Data

3.1 Electrical Interface - Input

| | |
|---------------|-----|
| Control input | PWM |
|---------------|-----|

Features

| | | |
|-----------------|----------------|----------------------------------|
| Input type | Open collector | |
| PWM - Frequency | | 1 kHz - 20 kHz typical: 2 kHz |

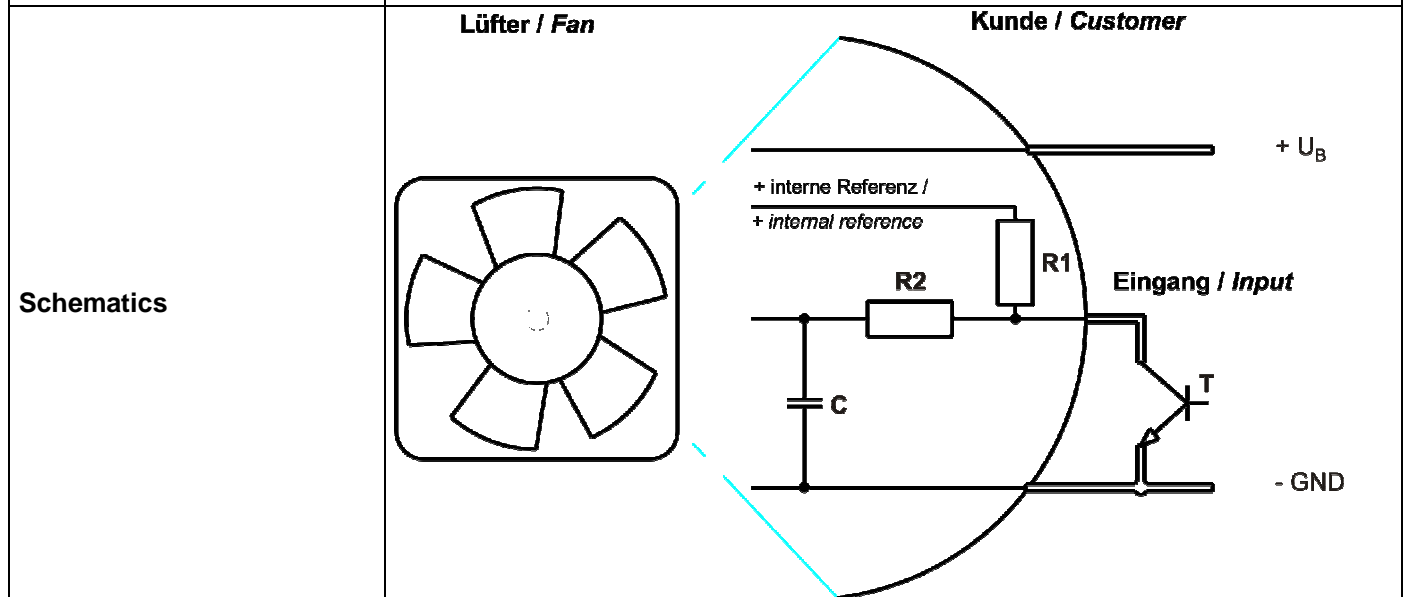
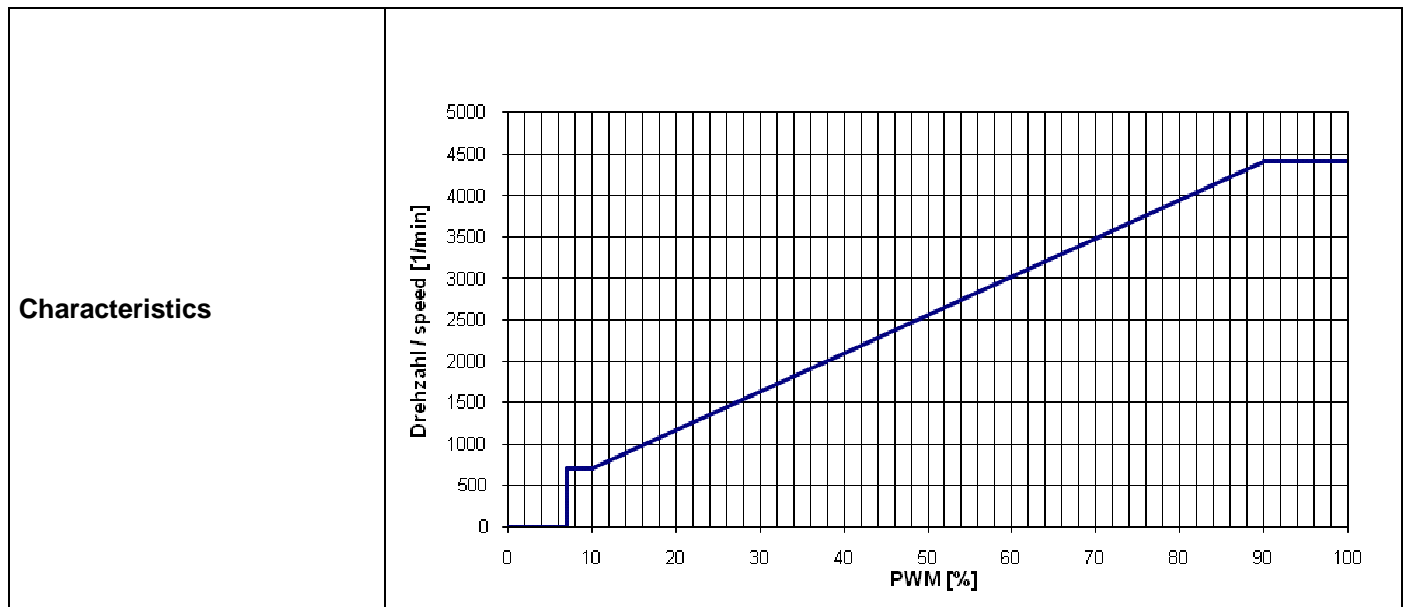

Transistor requirements:

Vce max. >= 12V; Isink max. >=5mA

Vce sat. <= 0,15V

Information to the curve:

| | |
|-----------------|---|
| 0% - 7% PWM: | 0 1/min |
| 7% - 10% PWM: | 700 1/min (corresponding to min. speed) |
| 10% - 90% PWM: | linear increasing curve |
| 90% - 100% PWM: | 4.400 1/min (corresponding to max. speed) |

3.2 Electrical Operating Data

Measurement conditions: Normal air density = 1,2 kg/m³; Temperature 23°C +/- 3°C; Motor axis horizontal; warm-up time before measuring 5 minutes (unless otherwise specified). In the intake and outlet area should not be any solid obstruction within 0,5 m.

$\Delta p = 0$: corresp. to free air flow (see chapter aerodynamics)
I: corresp. to arithm. mean current value

| Name | Condition |
|----------|----------------------|
| PWM 0001 | PWM: 100 %; f: 2 kHz |

| Features | Condition | Symbol | Values | | |
|---------------------|----------------|----------------|-------------|-------------|-------------|
| Voltage range | | U | 16 V | | 30 V |
| Nominal voltage | | U _N | | 24 V | |
| Power consumption | $\Delta p = 0$ | P | 13,4 W | 23 W | 23 W |
| Tolerance | PWM 0010 | | +/- 20 % | +/- 10 % | +/- 10 % |
| Current consumption | $\Delta p = 0$ | I | 840 mA | 950 mA | 780 mA |
| Tolerance | PWM 0010 | | +/- 20 % | +/- 10 % | +/- 10 % |
| Speed | $\Delta p = 0$ | n | 3.500 1/min | 4.400 1/min | 4.400 1/min |
| Tolerance | PWM 0010 | | +/- 10 % | +/- 5 % | +/- 5 % |

3.3 Electrical Interface - Output

| | |
|------------|---------------------|
| Tacho type | /2 (open collector) |
|------------|---------------------|

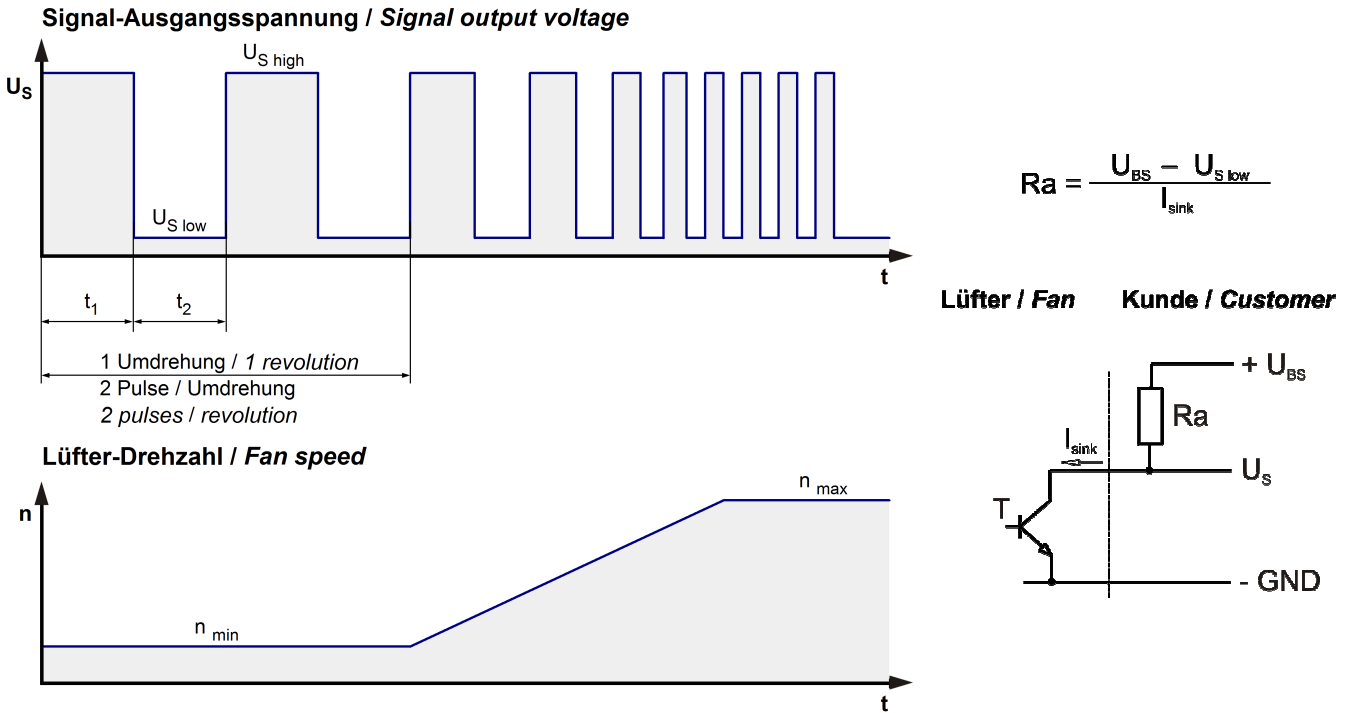

| Features | Note | Values |
|---------------------------|--|----------------------------|
| Tacho operating voltage | U_{BS} | $\leq 32,0\ V$ |
| Tacho signal Low | $U_{S\ low}$ | $\leq 0,4\ V$ |
| Tacho signal High | $U_{S\ high}$ | $\leq 32,0\ V$ |
| Maximum sink current | I_{sink} | $\leq 20\ mA$ |
| External resistor | External resistor R_a from U_{BS} to U_S required. All voltages measured to GND. | |
| Tacho frequency | $(2 \times n) / 60$ | |
| Tacho isolated from motor | No | |
| Slew rate | | $\Rightarrow 0,5\ V/\mu s$ |

n = revolutions per minute (1/min)

3.4 Electrical Features

| | | |
|--------------------------------|------------------------------------|--|
| Electronic function | Speed-Controlled | |
| Reversed polarity protection | Rectifying diode | |
| Max. residual current at U_N | $I_F \leq 5\ mA$ | |
| Locked rotor protection | Auto restart | |
| Locked rotor current at U_N | I_{block} approx. 900 mA | |
| Clock signal at locked rotor | t_3 / t_4 typical: 0,5 s / 5,0 s | |

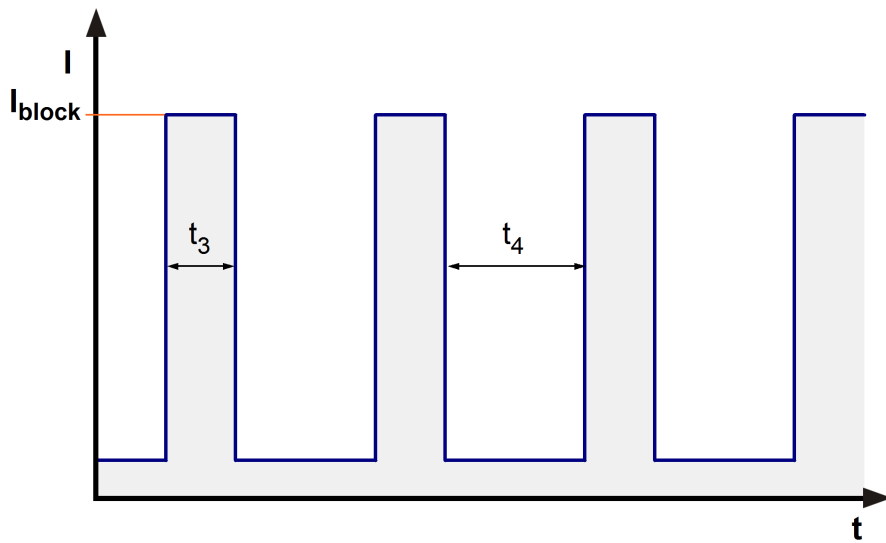
**Internal Fuse:**

Littlefuse NANO2(R) FUSE; Very fast acting 451 Series; 4 A

Note:

The internal electrolytic capacitor 470uF/35V has no resistor or inrush current limitation, essentially the power supply and the type and length of the connecting cable is limiting the Inrush current.

3.5 Aerodynamics

Measurement conditions:

Measured with a double chamber intake rig acc. to DIN EN ISO 5801.

Normal air density = 1,2 kg/m³; Temperature 23°C +/- 3°C;

In the intake and outlet area should not be any solid obstruction within 0,5 m. Motor shaft horizontal.

The information is only valid under the specified test conditions and may be changed by the installation conditions. If there are deviations from the standard test conditions, the characteristic values must be checked under the installed conditions. Power consumption of the fan motor when operating at normal voltage is shown. Depending on the operating conditions of the application, the power input may be higher.

a.) Operation condition:

| | | | |
|---|---------------------|-------------------------|--|
| 4.400 1/min at free air flow | PWM 100 %; f: 2 kHz | | |
| Max. free-air flow ($\Delta p = 0 / \dot{V} = \text{max.}$) | | 470,0 m ³ /h | |
| Max. static pressure ($\Delta p = \text{max.} / \dot{V} = 0$) | | 320 Pa | |

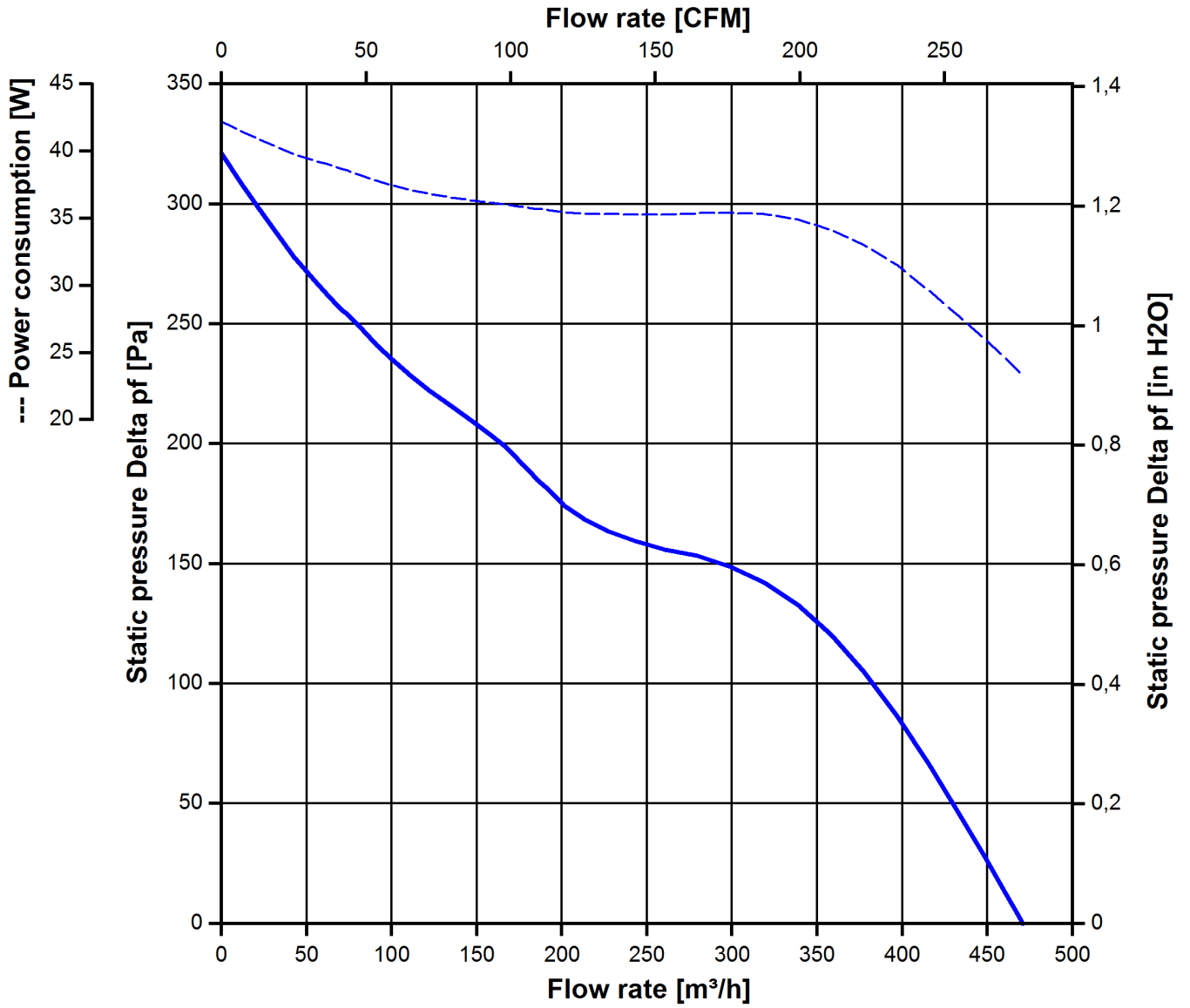

3.6 Sound Data

Measurement conditions: Sound pressure level: 1 meter distance between microphone and the air intake.
 Sound power level: Acc. to DIN 45635 part 38 (ISO 10302)
 Measured in a semianchoic chamber with a background noise level of $L_p(A) < 5 \text{ dB(A)}$
 For further measurement conditions see chapter aerodynamics.

a.) Operation condition:

| | | | |
|------------------------------|---------------------|--|--|
| 4.400 1/min at free air flow | PWM 100 %; f: 2 kHz | | |
|------------------------------|---------------------|--|--|

| | | |
|---|---------------------------------|--|
| Optimal operating point | 385,0 m ³ /h @ 88 Pa | |
| Sound power level at the optimal operating point | 6,5 bel(A) | |
| Sound pressure level at free air flow, measured in rubber bands | 56,0 dB(A) | |

4 Environment

4.1 General

| | | |
|--|--------|--|
| Min. permitted ambient temperature TU min. | -20 °C | |
| Max. permitted ambient temperature TU max. | 70 °C | |
| Min. permitted storage temperature TL min. | -40 °C | |
| Max. permitted storage temperature TL max. | 80 °C | |

4.2 Climatic Requirements

| | | |
|--------------------------------|---|--|
| IP-protection type (certified) | IP 68 (for fan only, not for connector if applicable) **) | |
| Humidity requirements | humid temperature, cyclic; according to DIN EN 60068-2-38, 10 cycle and condensation water check; according to DIN EN ISO 6270-2, 14 days | |
| Salt fog requirements | None | |

Permitted application area:

The product is for the use in partial sheltered rooms or open, roofed areas. Direct exposure to water is allowed provided that this does not prevent the normal operation. Saline ambient conditions must be avoided.

Pollution degree 3 (according DIN EN 60664-1)

It occurs conductive pollution or dry non-conductive pollution which becomes conductive due to condensation.

***) The specification of the IP protection refers to the conditions mentioned in certification of the fan. The above mentioned short description of the protection scope is not final. For detailed information of the respective protection scope and definitions, see certification as well as DIN EN 60529 (protection by housings) and ISO 20653 (for vehicles) with the letter K.

Short description of the IP-protection type:

Solid particle Protection: Dust tight.

Protection against deliberate contact: Protected against contact to hazardous parts with a wire.

Protection against water: The fan test according to IP68 (Based on IEC 60529), is conducted in non-operating mode. The fan is tested by a complete immersion in water for a period of 2h at a water-level of 1,2m. Electrical connections are not immersed since they are customer specific.

5 Safety

5.1 Electrical Safety

| | | |
|--|------------------|--|
| Dielectric strength DIN EN 60950 (VDE 0805) and DIN EN 60335 (VDE 0700) A.) Type test Measuring conditions: After 48h of storage at 95% R.H. and 25°C. No arcing or breakdown is allowed! All connections together to ground. | 500 VAC / 1 Min. | |
| B.) Routine test Measuring conditions: At indoor climate. No arcing or breakdown is allowed! All connections together to ground. | 850 VDC / 1 Sec. | |
| Isolation resistance Measuring conditions: After 48h of storage at 95% R.H. and 25°C measured with U=500 VDC for 1 min. | RI > 10 MOhm | |
| Clearance / creepage distance | 1,0 mm / 1,2 mm | |
| Protection class | III | |

5.2 Approval Tests

| | | |
|-----|---|---|
| CE | EC Declaration of Conformity | Yes |
| EAC | Eurasian Conformity | Yes |
| UL | Underwriters Laboratories | Yes / UL507, Electric Fans |
| VDE | Association for Electrical, Electronic and Information Technologies | Yes / Approval acc. to EN 60950 (VDE 0805) - Information technology equipment |
| CSA | Canadian Standards Association | Yes / C22.2 No. 113 Fans and Ventilators |
| CCC | China Compulsory Certification | Not applicable |

6 Reliability

6.1 General

| | | |
|--|-----------|--|
| Life expectancy L10 at TU = 40 °C | 80.000 h | |
| Life expectancy L10 at TU max. | 40.000 h | |
| Life expectancy L10 acc. to IPC 9591 at TU = 40 °C | 135.000 h | |

3.) Schraube Duo-Tapptite nach DIN 7500; CM4x8; Torx screw: Duo-Tapptite according to DIN 7500; CM4x8; Torx

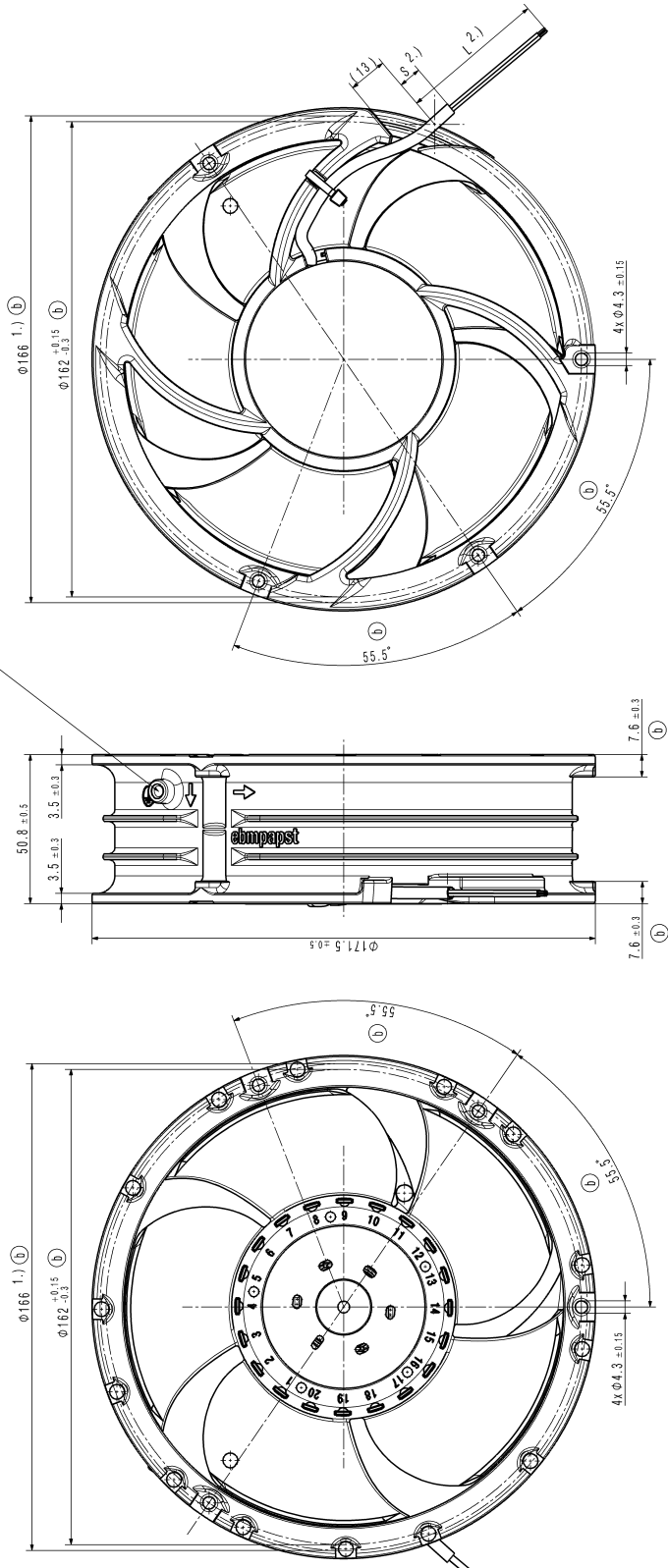

- 1.) Maße aus Montageausschnitt
- 2.) Anzahl und Länge der Litzen/Schlauch siehe Produktspezifikation
- 3.) Nur wenn in Stückliste enthalten

- Axialspiel der Kugellager mit Feder spielfrei gelagert

- 1.) measures of mounting cut out
- 2.) length an number of wires/tube see product specification
- 3.) only if it is included in bill of material

- ball bearing without clearance by a pre-load spring

Rechte an diesem Dokument, das gezeichnet ist, werden nicht übertragen. Die Verwendung dieses Dokuments ist an die Bereitstellung der entsprechenden Informationen gebunden. Die Rechte an diesem Dokument werden durch die Hersteller der Bauteile vorbehalten.

| | | | |
|---|--|---|--|
| Zeichnen / Rev. Nr. / Datum / Blatt Nr. | | Gezeichnet / Rev. Nr. / Datum / Blatt Nr. | |
| Konstruktion / Projekt / Material | | | |
| Fertigung / Material | | | |
| Besondere Anmerkungen | | | |
| Abmessungen / mm | | Fertigung / mm | |
| Gewicht / kg | | Material / mm | |
| Hersteller: ebmpapst | | | |
| www.ebmpapst.de | | | |