

1 General

Fan type	Fan
Rotating direction looking at rotor	Counterclockwise
Airflow direction	Air outlet over struts
Bearing system	Ball bearing
Mounting position - shaft	Any
Balancing grade	40,0

2 Mechanics**2.1 General**

Width	119,0 mm	
Height	119,0 mm	
Depth	25,0 mm	
Diameter	0,0 mm	
Mass	0,320 kg	
Housing material	Metal	
Impeller material	Plastic	
Max. torque when mounted across both mounting flanges	Wire outlet corner: 110 Ncm Remaining corners: 380 Ncm	
Screw size	ISO 4762 - M4 degreased, without an additional brace and without washer	

2.2 Connections

Electrical connection	Plug	
Lead wire length	See drawing	
Tolerance		
Tube length	See drawing	
Tolerance		
Wire size (AWG)		
Insulation diameter		
Plug	See drawing	
Contact	See drawing	

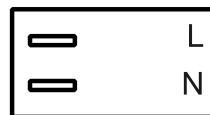

3 Operating Data

3.1 Electrical Operating Data

Measurement conditions: Normal air density = 1,2 kg/m³; Temperature 23°C +/- 3°C; Motor axis horizontal; warm-up time before measuring 5 minutes (unless otherwise specified).
In the intake and outlet area should not be any solid obstruction within 0,5 m.

$\Delta p = 0$: corresp. to free air flow (see chapter aerodynamics)

I: corresp. to RMS line current

Features	Condition	Symbol	Values	
Frequency	$\Delta p = 0$	f	50 Hz	60 Hz
Nominal voltage	$\Delta p = 0$	U_N	230 V	230 V
Tolerance			+ 6 % - 10 %	+ 6 % - 10 %
Power consumption	$\Delta p = 0$	P	10 W	8 W
Tolerance			+ 5 % - 10 %	+ 5 % - 10 %
Speed	$\Delta p = 0$	n	2.250 1/min	2.450 1/min
Tolerance			+/- 5 %	+/- 5 %

3.4 Sound Data

Measurement conditions: Sound pressure level: 1 meter distance between microphone and the air intake.
 Sound power level: Acc. to DIN 45635 part 38 (ISO 10302) Sound power level: Acc. to DIN 45635 part 38 (ISO 10302)
 Measured in a semianchoic chamber with a background noise level of $L_p(A) < 5 \text{ dB}(A)$
 For further measurement conditions see chapter aerodynamics.

a.) Operation condition:

2.250 1/min at free air flow

Frequency: 50 Hz

Optimal operating point	74,0 m ³ /h @ 12 Pa	
Sound power level at the optimal operating point	4,7 bel(A)	
Sound pressure level at free air flow, measured in rubber bands	37,0 dB(A)	

b.) Operation condition:

2.450 1/min at free air flow

Frequency: 60 Hz

Optimal operating point	70,0 m ³ /h @ 15 Pa	
Sound power level at the optimal operating point	4,9 bel(A)	
Sound pressure level at free air flow, measured in rubber bands	40,0 dB(A)	

4 Environment

4.1 General

Min. permitted ambient temperature TU min.	-40 °C / 50 Hz -40 °C / 60 Hz	
Max. permitted ambient temperature TU max.	80 °C / 50 Hz 80 °C / 60 Hz	
Min. permitted storage temperature TL min.	-40 °C	
Max. permitted storage temperature TL max.	80 °C	

4.2 Climatic Requirements *)

Humidity requirements	humid heat, cyclic; according to DIN EN 60068-2-30, 6 cycle	
Water exposure	None	
Dust requirements	Dust check; according to DIN EN 60068-2-68, 6g/m ² d, 1 day	
Salt fog requirements	None	

Permitted application area:

The product is for the use in sheltered rooms with limited controlled temperature. Occasionally condensed water is allowed. Direct exposure to water must be avoided. Saline ambient conditions must be avoided.

Pollution degree 2 (according DIN EN 60664-1)

It occurs only non-conductive pollution. Occassionally, temporary conductivity caused by condensation occurs.

5 Safety

5.1 Electrical Safety

Dielectric strength DIN EN 60950 (VDE 0805) and DIN EN 60335 (VDE 0700) A.) Type test Measuring conditions: After 48h of storage at 95% R.H. and 25°C. No arcing or breakdown is allowed! All connections together to ground.	1500 VAC / 1 Min.
B.) Routine test Measuring conditions: At indoor climate. No arcing or breakdown is allowed! All connections together to ground.	1500 VAC / 1 Sec.
Isolation resistance Measuring conditions: After 48h of storage at 95% R.H. and 25°C measured with U=500 VDC for 1 min.	RI > 50 MOhm
Clearance / creepage distance	2,0 mm / 1,8 mm
Protection class	I

5.2 Approval Tests

CE	EC Declaration of Conformity	Yes
EAC	Eurasian Conformity	Yes
UL	Underwriters Laboratories	Yes / UL507, Electric Fans
VDE	Association for Electrical, Electronic and Information Technologies	Yes / Approval acc. to EN 60335 (VDE 0700) - Safety for household and similar electrical appliances
CSA	Canadian Standards Association	Yes / C22.2 No. 113 Fans and Ventilators
CCC	China Compulsory Certification	Yes / GB 12350 Safety Requirements for small Power Motors

The approval tests are observed to:

U approval max.: 230 V / f: 50 and 60 Hz @ TU approval max.: 80 °C

6 Reliability

6.1 General

Life expectancy L10 at TU = 40 °C	57.500 h / 50 Hz 62.500 h / 60 Hz	
Life expectancy L10 at TU max.	22.500 h / 50 Hz 25.000 h / 60 Hz	

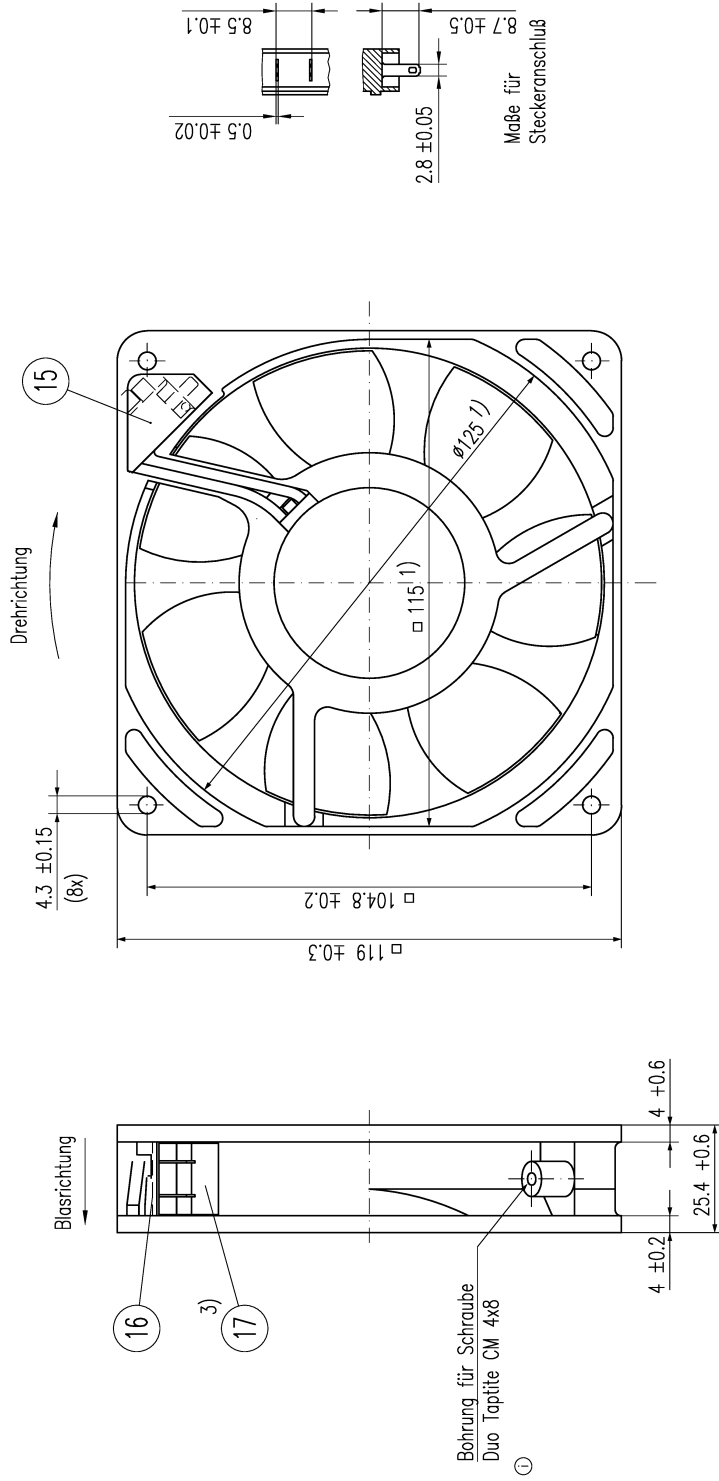

- 1) Maße für Montagewand
3) mit Pos. 23 geklebt

Axialspiel bei
– Kugellagerung (K): 0 (mit Federausgleich)
– Gleitlagerung (G): 0.1 – 0.6

Tolerierung: Allgemeintoleranzen:		DIN ISO 2768-mK-E		Maßstab	
i		Datum	Name	Artikel	
h		Erstellt			
g		Geprüft			
f					
Index	And.-Nr.	Datum	Geändert von	Zchg.-Nr.	Blatt
			PAPST		
			PAPST-MOTOREN GmbH & Co KG		
			D-8172 St. Georgen		
			Germany		
von		am		Est.Zölg.	