

Nominal data

Type	A4D350-AP08-02				
Motor	M4D074-DF				
Phase		3~	3~	3~	3~
Nominal voltage	VAC	230	230	400	400
Connection		Δ	Δ	Y	Y
Frequency	Hz	50	60	50	60
Type of data definition		fa	fa	fa	fa
Valid for approval / standard		CE	CE	CE	CE
Speed	min ⁻¹	1410	1600	1410	1600
Power input	W	130	180	130	180
Current draw	A	0.61	0.59	0.35	0.34
Max. back pressure	Pa	90	90	90	90
Max. ambient temperature	°C	50	40	50	40

ml = max. load · me = max. efficiency · fa = running at free air · cs = customer specs · cu = customer unit
Subject to alterations

Data according to ErP directive

Installation category	A	Overall efficiency η_{es}	Actual	Request 2013	Request 2015
Efficiency category	Static	Efficiency grade N	30.7	24.5	28.5
Variable speed drive	No	Power input P_e	42.2	36	40
Specific ratio*	1.00	Power input P_e	kW	0.15	
		Air flow q_v	m ³ /h	2110	
		Pressure increase p_{fs}	Pa	80	
		Speed n	min ⁻¹	1385	

Data established at point of optimum efficiency

Technical features

Size	350 mm
Surface of rotor	Coated in black
Material of blades	Sheet steel, coated in black
Number of blades	5
Direction of air flow	"A"
Direction of rotation	Clockwise, seen on rotor
Type of protection	IP 44; Depending on installation and position
Insulation class	"B"
Humidity class	F1-2
Max. permissible ambient motor temp. (transp./ storage)	+ 80 °C
Min. permissible ambient motor temp. (transp./storage)	- 40 °C
Mounting position	Shaft horizontal or rotor on bottom; rotor on top on request
Condensate discharge holes	Rotor-side
Operation mode	S1
Motor bearing	Ball bearing
Touch current acc. IEC 60990 (measuring network Fig. 4, TN system)	< 0.75 mA
Cable exit	Variable
Protection class	I (if protective earth is connected by customer)
Product conforming to standard	EN 60335-1
Approval	CCC

Product drawing

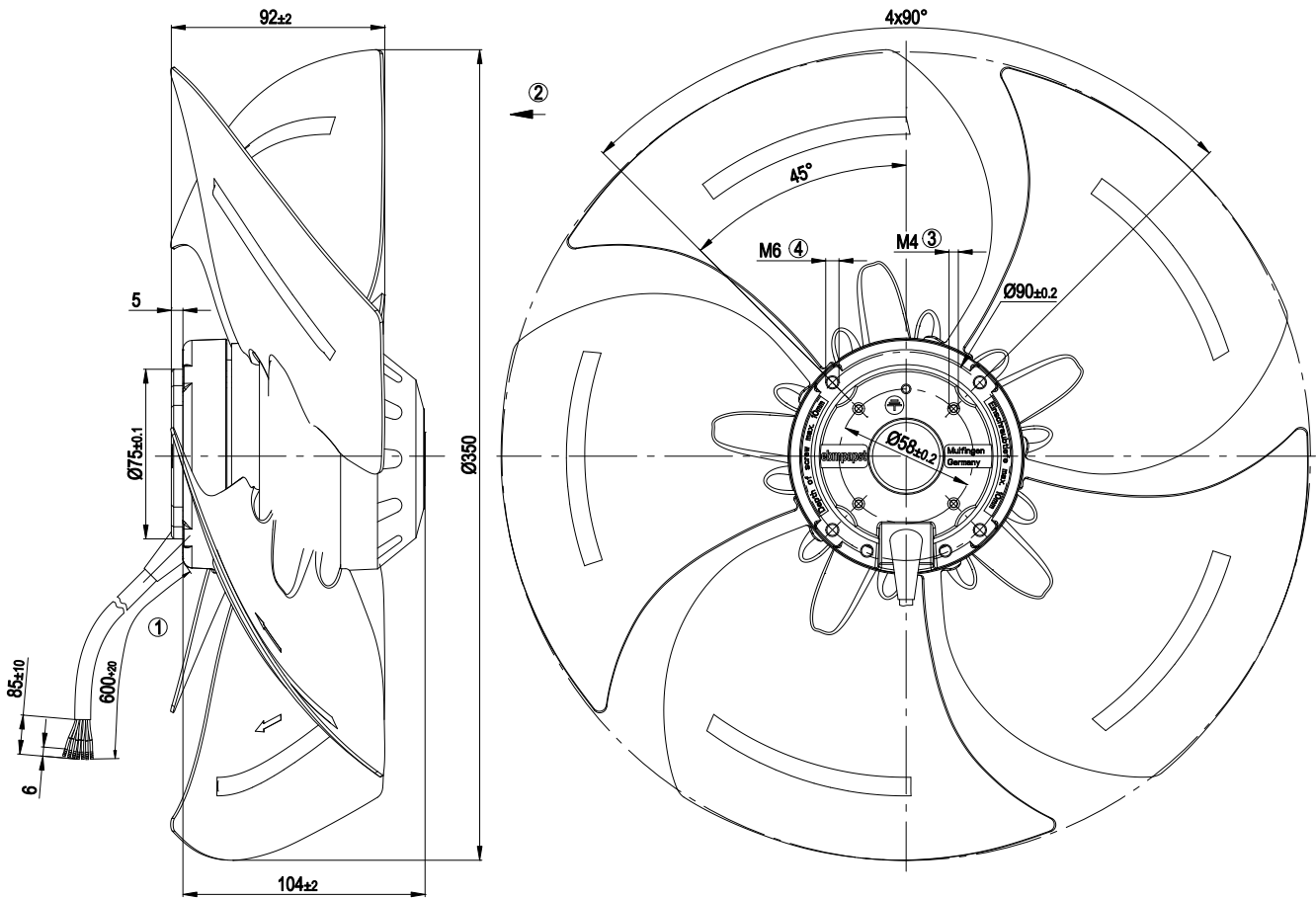

1	Connection line PVC, 7x brass lead tips crimped
2	Direction of air flow "A"
3	Depth of screw max. 5 mm
4	Depth of screw max. 10 mm

Connection screen

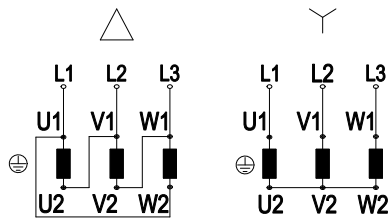

Note: Direction of rotation changes when two phases are reversed

Δ	Delta connection	Y	Star connection	L1	black
L2	blue	L3	brown	U1	black
V1	blue	W1	brown	U2	green
V2	white	W2	yellow		

Charts: Air flow 50 Hz

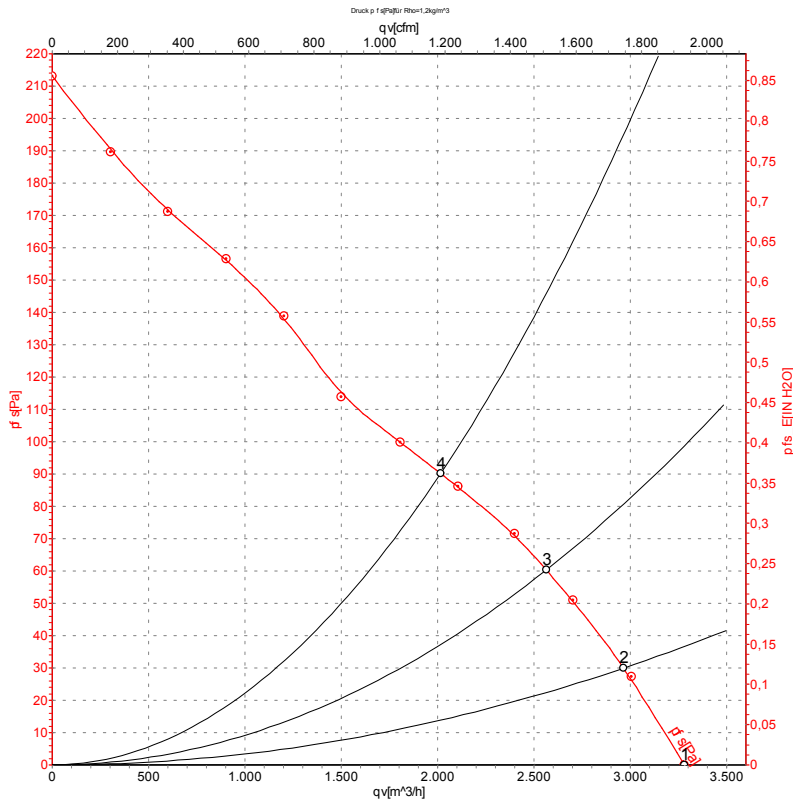

Measurement: LU-122615

Air performance measured as per ISO 5801 Installation category A. For detailed information on the measuring set-up, please contact ebm-papst. Suction-side noise levels: L_{wA} measured as per ISO 13347 / L_{pA} measured with 1m distance to fan axis. The values given are valid under the measuring conditions mentioned above and may vary according to the actual installation situation. With any deviation from the standard set-up, the specific values have to be checked and reviewed with the unit installed.

Measured values

	Conn.	U	f	n	P _e	I	qv	p _{fs}
		V	Hz	min ⁻¹	W	A	m ³ /h	Pa
1	Y	400	50	1410	130	0.35	3280	0
2	Y	400	50	1395	145	0.35	2965	30
3	Y	400	50	1380	158	0.36	2565	60
4	Y	400	50	1355	179	0.38	2015	90

Conn. = Connection · U = Supply voltage · f = Frequency · n = Speed · P_e = Power input · I = Current draw · qv = Air flow · p_{fs} = Pressure increase



Charts: Air flow 60 Hz

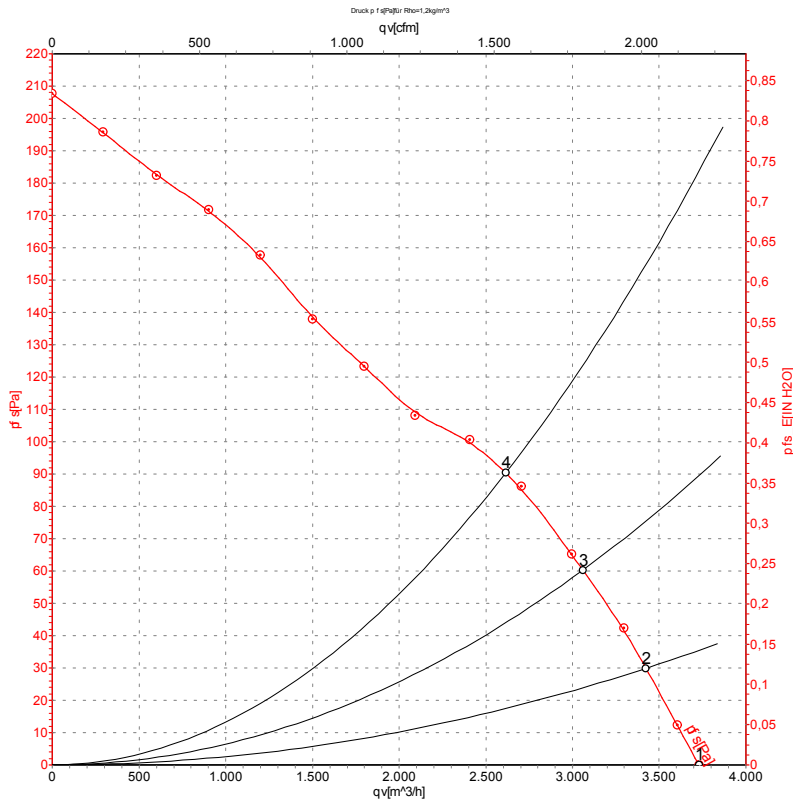

Measurement: LU-122616

Air performance measured as per ISO 5801 Installation category A. For detailed information on the measuring set-up, please contact ebm-papst. Suction-side noise levels: LwA measured as per ISO 13347 / LpA measured with 1m distance to fan axis. The values given are valid under the measuring conditions mentioned above and may vary according to the actual installation situation. With any deviation from the standard set-up, the specific values have to be checked and reviewed with the unit installed.

Measured values

	Conn.	U	f	n	Pe	I	qv	pfs
		V	Hz	min ⁻¹	W	A	m ³ /h	Pa
1	Y	400	60	1600	180	0.34	3730	0
2	Y	400	60	1585	196	0.35	3425	30
3	Y	400	60	1555	214	0.37	3060	60
4	Y	400	60	1525	232	0.40	2615	90

Conn. = Connection · U = Supply voltage · f = Frequency · n = Speed · Pe = Power input · I = Current draw · qv = Air flow · pfs = Pressure increase

