

Nominal data

Type	A6E500-BB05-10				
Motor	M6E094-FA				
Phase		1~	1~	1~	1~
Nominal voltage	VAC	230	230	230	230
Frequency	Hz	50	50	60	60
Type of data definition		ml	ml	ml	ml
Valid for approval / standard		CE	CE	CE	CE
Speed	min ⁻¹	845	845	875	875
Power input	W	220	220	290	290
Current draw	A	0.98	0.98	1.27	1.27
Motor capacitor	μF	6	6	6	6
Capacitor voltage	VDB	400	400	400	400
Capacitor standard		P0 (CE)	P0 (CE)	P0 (CE)	P0 (CE)
Max. back pressure	Pa	60	60	60	60
Min. ambient temperature	°C	-40	-40	-40	-40
Max. ambient temperature	°C	95	95	80	80

ml = max. load · me = max. efficiency · fa = running at free air · cs = customer specs · cu = customer unit
Subject to alterations

Data according to ErP directive

Installation category	A
Efficiency category	Static
Variable speed drive integrated	No
Specific ratio*	1,00

* Specific ratio = $1 + p_e / 100\,000\text{ Pa}$

	Actual	Request 2013	Request 2015
Overall efficiency η_{es}	29,4	25,4	29,4
Efficiency grade N	40	36	40
Power input P_e	kW	0,21	
Air flow q_v	m ³ /h	3770	
Pressure increase p_{fs}	Pa	60	
Speed n	min ⁻¹	850	

Data established at point of optimum efficiency

Technical features

Size	500 mm
Surface of rotor	Coated in black
Material of blades	Sheet steel, coated in black
Number of blades	5
Direction of air flow	"V"
Direction of rotation	Counter-clockwise, seen on rotor
Type of protection	IP 54
Insulation class	"F"
Humidity class	F3-1
Max. permissible ambient motor temp. (transp./ storage)	+ 80 °C
Min. permissible ambient motor temp. (transp./storage)	- 40 °C
Mounting position	Shaft horizontal or rotor on bottom; rotor on top on request
Condensate discharge holes	Rotor-side
Operation mode	S1
Motor bearing	Ball bearing
Leakage current	<= 3.5 mA
Motor protection	Thermal overload protector (TOP) brought out
Cable exit	Variable
Protection class	I (if protective earth is connected by customer)
Product conforming to standard	EN 60034-1 (2004)

Product drawing

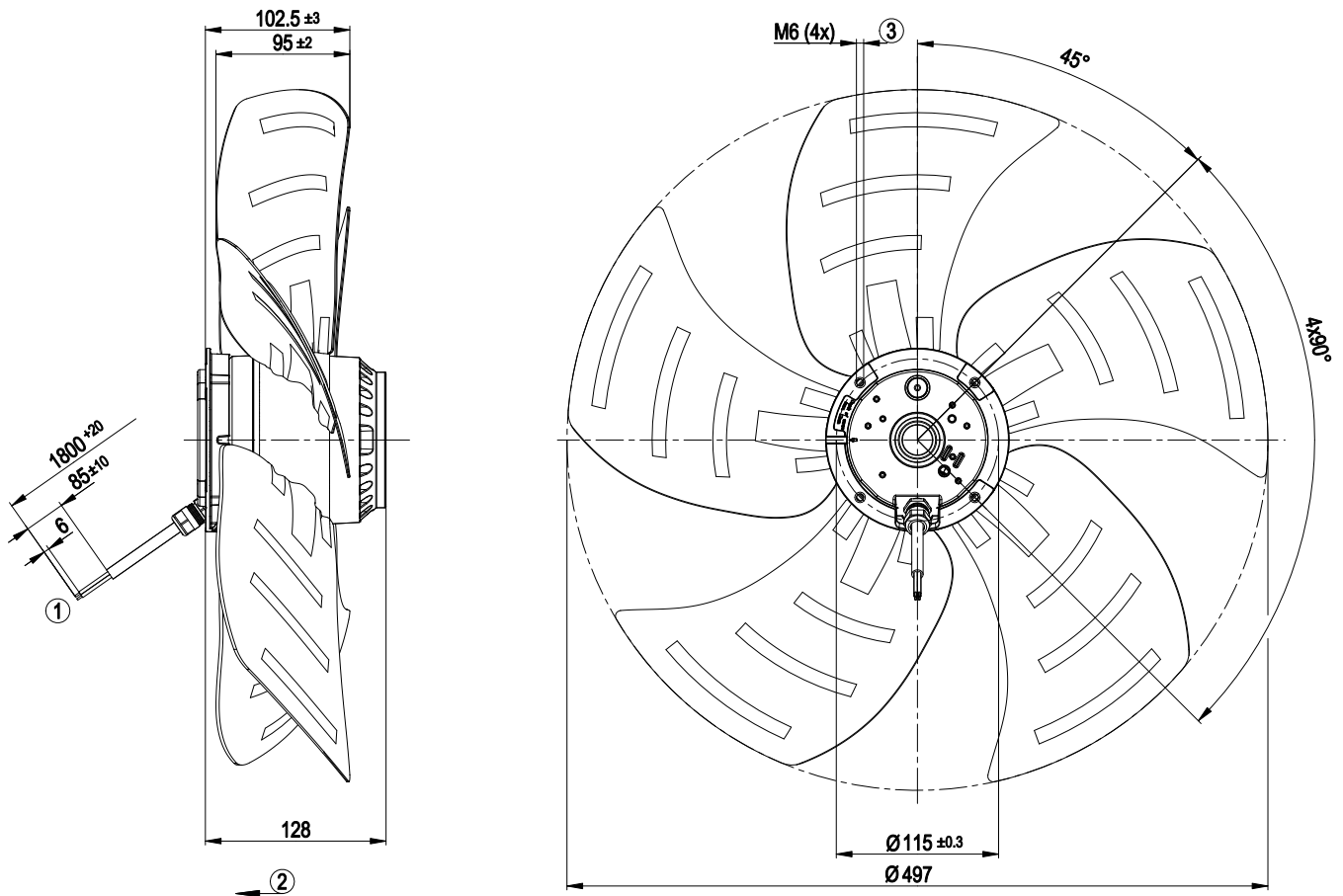

1	Connection line silicone 6G 0.50 mm ² , 6x brass lead tips crimped
2	Direction of air flow "V"
3	Depth of screw max. 12 mm

Connection screen

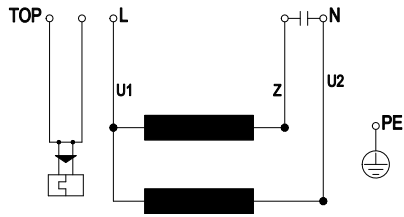

TOP	2 x grey	U1	blue	Z	brown
U2	black	PE	green / yellow		

Charts: Air flow 50 Hz

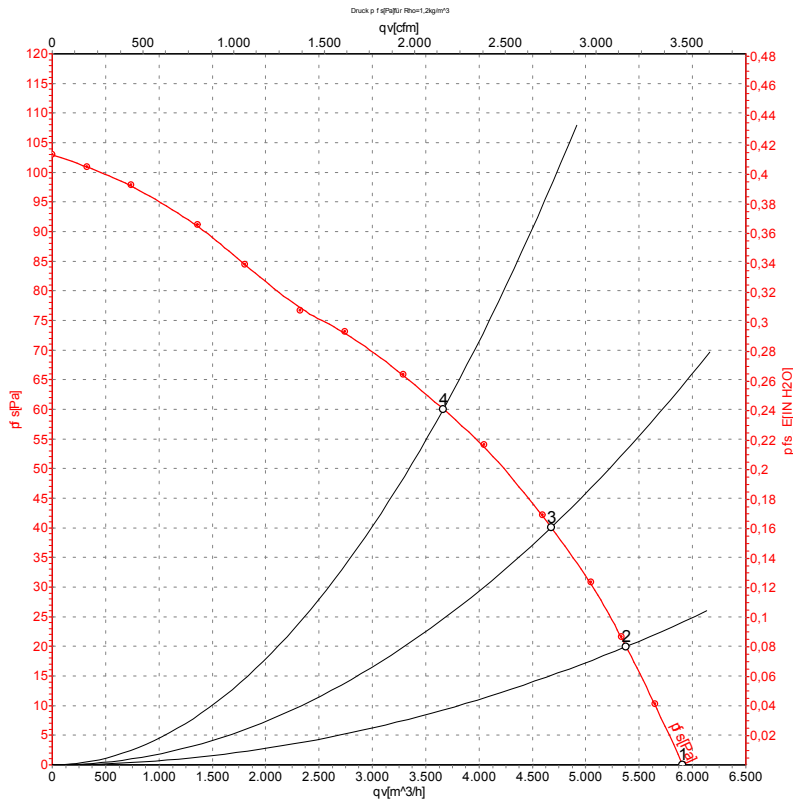

Measurement: LU-52337

Air performance measured as per ISO 5801 Installation category A. For detailed information on the measuring set-up, please contact ebm-papst. Suction-side noise levels: L_{wA} measured as per ISO 13347 / L_{pA} measured with 1m distance to fan axis. The values given are valid under the measuring conditions mentioned above and may vary according to the actual installation situation. With any deviation from the standard set-up, the specific values have to be checked and reviewed with the unit installed.

Measured values

	U	f	n	P _e	I	qv	P _{fs}
	V	Hz	min ⁻¹	W	A	m ³ /h	Pa
1	230	50	895	190	0.84	5900	0
2	230	50	880	199	0.88	5375	20
3	230	50	865	211	0.93	4675	40
4	230	50	845	220	0.98	3665	60



Charts: Air flow 60 Hz

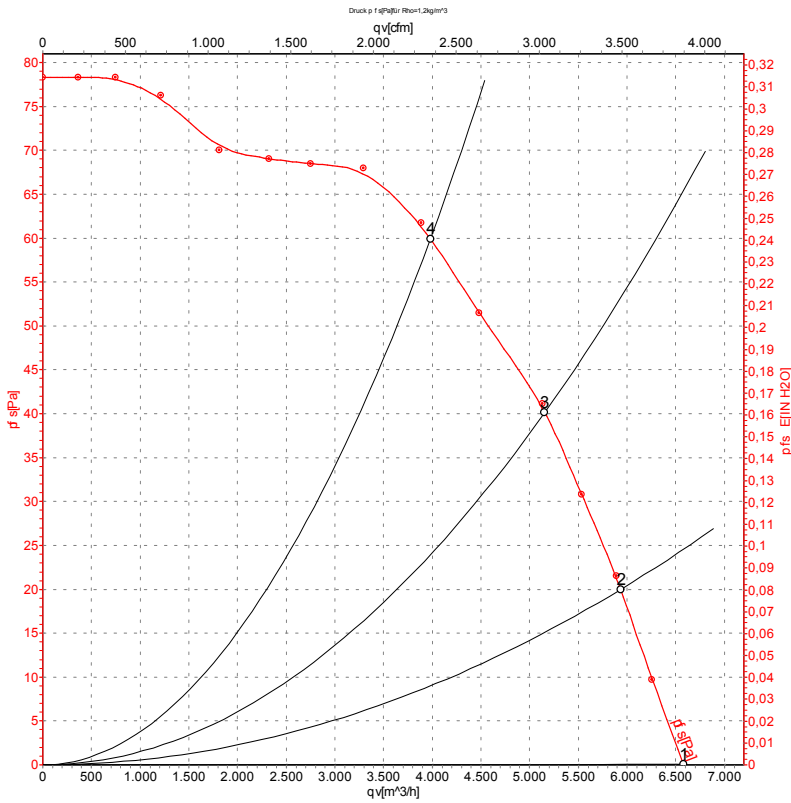

Measurement: LU-52336

Air performance measured as per ISO 5801 Installation category A. For detailed information on the measuring set-up, please contact ebm-papst. Suction-side noise levels: L_{wA} measured as per ISO 13347 / L_{pA} measured with 1m distance to fan axis. The values given are valid under the measuring conditions mentioned above and may vary according to the actual installation situation. With any deviation from the standard set-up, the specific values have to be checked and reviewed with the unit installed.

Measured values

	U	f	n	P _e	I	qv	P _{fs}
	V	Hz	min ⁻¹	W	A	m ³ /h	Pa
1	230	60	995	267	1.16	6580	0
2	230	60	960	277	1.20	5935	20
3	230	60	925	284	1.23	5155	40
4	230	60	875	290	1.27	3980	60

