





 Ghisa EN-GJL-250
 Fonte EN-GJL-250
 Hierro fundido EN-GJL-250

 Cast Iron EN-GJL-250
 Grauguss EN-GJL-250
 Чугун EN-GJL-250

Curva caratteristica - Performance curve - Courbe caractéristique
Kennlinie - Curva característica - Характеристическая кривая

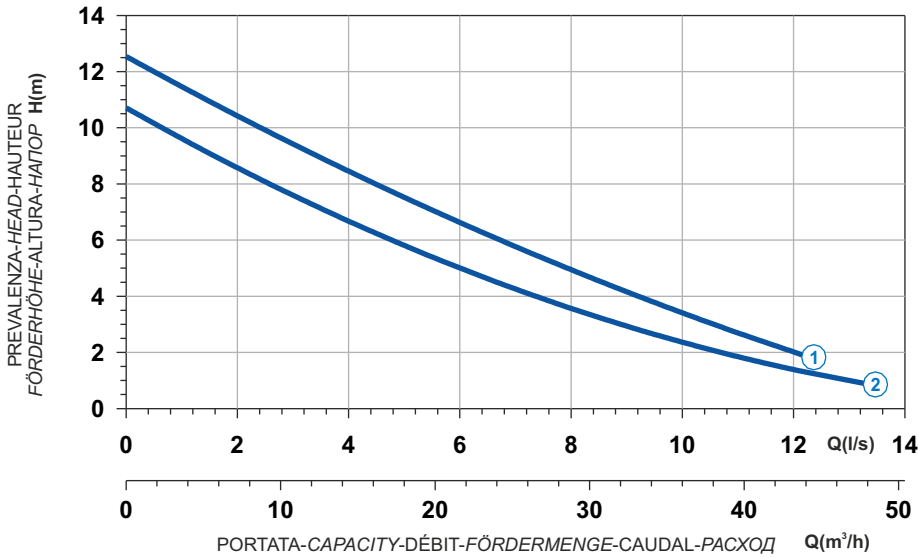

Curve N°	Code	Type	MOTOR			ATEX code 
			Rated power P2 (kW)	Rated current I (A)	Starting current Is (A)	
1	7003121	G271T6V2-L65AA0	2,1	3,9	23	7000403
2	7000554	G271T6V3-L65AA0	1,8	3,5	17,2	7000839

Power supply	3ph 400V 50Hz
R.P.M.	2850
Free passage (mm)	65
Discharge (mm)	DN 65
Max Weight (Kg)	44

Dimensioni - Dimensions - Dimensions - Abmessungen - Dimensiones - Габариты (mm)

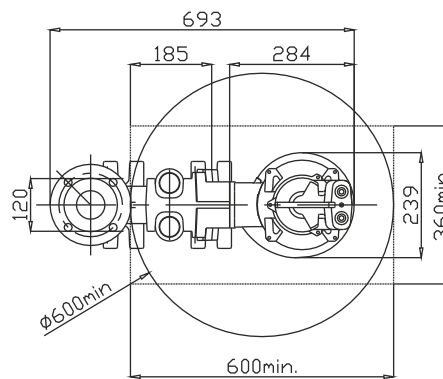
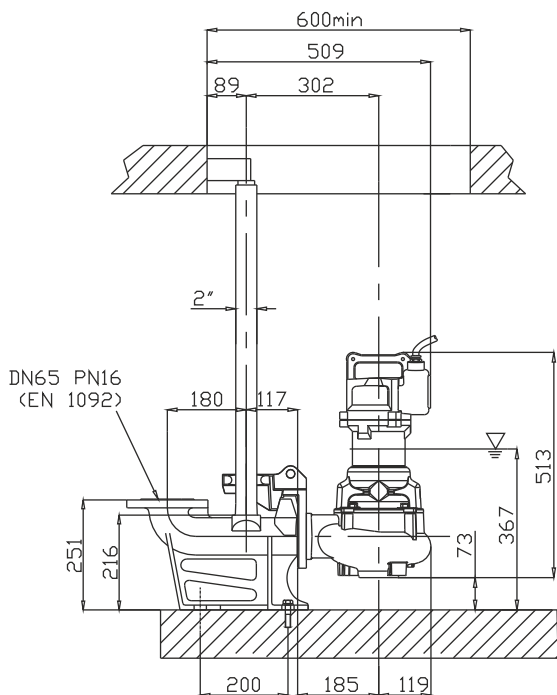

▽ LIVELLO MINIMO DI SOMMERGIBILITÀ
 MINIMUM SUBMERSIBLE LEVEL
 NIVEAU MINIMUM D'IMMERSION
 MINDESTWASSERSTAND
 NIVEL SUMERGIBLE MÍNIMO
 МИНИМАЛЬНАЯ ГЛУБИНА ПОГРУЖЕНИЯ

